

Hydrogen Bonding in *ortho*-Substituted Biphenyls¹

William F. Baitinger, Jr.,² Paul von R. Schleyer,³ and Kurt Mislow

Contribution from the Department of Chemistry, Princeton University, Princeton, New Jersey 08540. Received January 13, 1965

The hydrogen bonding spectra of a number of biphenyls with OH or CH₂OH groups attached to the 2- and 2'-positions were examined. In these compounds, intramolecular OH···O hydrogen bonding is possible only in certain conformations, and an analysis of the spectra permits conformational assignments to be made. It was concluded that 2,2'-dihydroxybiphenyl (**2**) prefers the *cis* conformation (II), but that 6,6'-substituted derivatives of the same compound exist in more nearly perpendicular arrangements (I). Analysis of the spectra of 2,2'-dimethylolbiphenyls (**7** and **8**) was facilitated by comparison with conformationally fixed bridged biphenyls (**9**). In this instance, the hydrogen bonding method of conformational analysis was superior to o.r.d., which could not establish with certainty the fact that compounds **7a-c**, **8**, and **9** all had similar average conformations. The unconstrained 2,2'-dimethylolbiphenyls **7a-c** and **8** probably exist in more nearly perpendicular conformations than do the *cis*-restricted analogs **9**. Hydrogen bonding spectra confirmed the earlier o.r.d. conclusion that 6,6'-dinitro-2,2'-dimethylolbiphenyl (**7d**) was unique in preferring the *trans* conformation (III). The spectra of related biphenyls were also interpreted. Compound **10** shows a variety of intramolecular hydrogen bonding interactions, while **13** and **14** provide particularly favorable examples of OH··· π hydrogen bonding.

Substituted biphenyls provide the classic examples of hindered rotation about C-C single bonds.⁴ Unbridged biphenyls with bulky *ortho* substituents can be prepared in optically active form, demonstrating their nonplanarity. The determination of configuration and conformation of substituted biphenyls by a variety of physical methods has been the subject of numerous investigations in recent years.⁵

Stated in general terms, the problem of conformational preference⁵ is to decide which one of three average conformations (I, II, or III) is adopted by the biphenyl system under the conditions of measurement. Spectroscopic and diffraction methods have shown that the *cis* conformation is generally favored over the *trans* conformation in 2,2'-disubstituted biphenyls, *i.e.*, II is preferred over III when X = H.⁵ However, o.r.d. studies have suggested^{6b} that the *trans* conformation (III) may be the more stable form of tetrasubstituted, unbridged, 2,2'-dinitrobiphenyls.

(1) Paper XIV of a series on hydrogen bonding; paper XIII: W. F. Baitinger, Jr., P. von R. Schleyer, T. S. S. R. Murty, and L. Robinson, *Tetrahedron*, **20**, 1635 (1964). Taken in part from the Ph.D. Thesis of W. F. B., Princeton University, 1964.

(2) American Cyanamid Junior Research Fellow, 1960-1962; National Institutes of Health Predoctoral Fellow, 1962-1963.

(3) Alfred P. Sloan Research Fellow, 1962-1966; J. S. Guggenheim Fellow, 1964-1965; Fulbright Research Fellow, 1964-1965.

(4) E. L. Eliel, "Stereochemistry of Carbon Compounds," McGraw-Hill Book Co., Inc., New York, N. Y., 1962, Chapter 6.

(5) For leading references, see (a) K. Mislow, M. A. W. Glass, H. B. Hopps, E. Simon, and G. H. Wahl, Jr., *J. Am. Chem. Soc.*, **86**, 1710 (1964); (b) K. Mislow, M. A. W. Glass, R. E. O'Brien, P. Rutkin, D. H. Steinberg, J. Weiss, and C. Djerassi, *ibid.*, **84**, 1455 (1962).

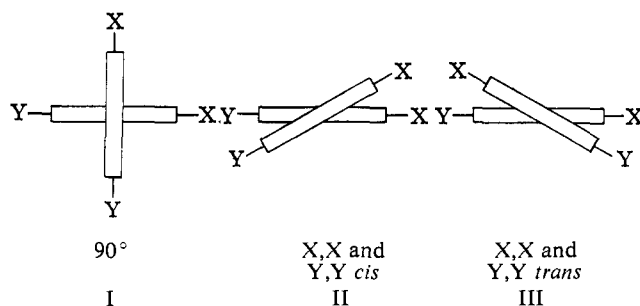

Infrared spectroscopic investigations of intramolecular hydrogen bonding in appropriately substituted biphenyls provide an independent means for determining conformation. In particular, if groups capable of forming hydrogen bonds are attached to the 2- and 2'-positions of a biphenyl, bonding between them can only occur in *cis* (II) and not in *trans* (III) conformations. Previous applications of this hydrogen bonding technique in biphenyls have largely been limited to 2,2'-dihydroxy derivatives (Table I)⁶⁻¹³ and similar compounds.^{8b} We have examined here in addition a number of bridged and unbridged 2,2'-dimethylolbiphenyls (I-III, X = CH₂OH) and related substances.

Spectroscopic Determinations and Assignments. Infrared spectra were determined in dilute CCl₄ solutions in the hydroxyl stretching region, 2.7-3.0 μ , using instruments capable of high resolution. Concentrations of compounds 0.005 *M* or less were employed to ensure the observation of intramolecular hydrogen bonding free from intermolecular interferences. Two concentrations were used as a further check. The results are summarized in Tables I-III, which include data for model compounds and comparisons with literature values where these are available.

The spectrum of 2,2'-dihydroxybiphenyl (**2**, Figure 1a) is illustrative. Three bands are observed. The weak peak at 3597 cm.⁻¹ is characteristic of the free peak of phenols. The band at 3553 cm.⁻¹ is attributed to OH··· π hydrogen bonding involving the OH groups of one ring and the π -electrons of the other, since 2-phenylphenol (**1**) gives a spectrum which has two bands similarly displayed.⁶⁻¹³ The third peak of **2**, strongly shifted to 3470 cm.⁻¹, must be due to an OH···O interaction between the hydroxyl groups.^{8a,11,13}

(6) M. Oki and H. Iwamura, *Bull. Chem. Soc. Japan*, **34**, 1395 (1961).

(7) W. Beckering, *J. Phys. Chem.*, **65**, 206 (1961).

(8) (a) H. Musso and H. Matthies, *Ber.*, **94**, 356 (1961); H. Musso and S. von Grunelius, *ibid.*, **92**, 3101 (1959); (b) H. Musso and G. Sandrock, *ibid.*, **97**, 2076 (1964).

(9) A. W. Baker and A. T. Shulgin: (a) *J. Am. Chem. Soc.*, **80**, 5358 (1958); (b) *Spectrochim. Acta*, **19**, 1611 (1963).

(10) V. Keussler and G. Rossmly, *Z. Elektrochem.*, **60**, 136 (1956).

(11) R. E. Richards and H. W. Thompson, *J. Chem. Soc.*, 1260 (1947).

(12) O. Wulf, U. Liddel, and S. Hendricks, *J. Am. Chem. Soc.*, **58**, 2287 (1936).

(13) C. Wintner, A.B. Thesis, Princeton University, 1959.

Table I. Spectroscopic Data for Hydroxybiphenyls

| No. | Compound | ν free | ν OH \cdots π | $\Delta\nu$ | ν OH \cdots O | $\Delta\nu$ | Ref. | | |
|--------|--------------------------------|---------------|----------------------------|-------------|------------------------|-------------|--------------|-----|--------------|
| 1 | 2-Phenylphenol | 3607 | 3565 | 42 | | | Present work | | |
| | | 3606 | 3567 | 39 | | | 13 | | |
| | | 3603 | 3558 | 45 | | | 6 | | |
| | | 3609 | 3568 | 41 | | | 7 | | |
| | | (3600) | (3546) | (54) | | | 8a | | |
| | | 3603 | 3558 | 45 | | | 9a | | |
| | | 3608 | 3565 | 43 | | | 9b | | |
| | | 3610 | 3563 | 47 | | | 10 | | |
| | | (3610) | (3590) | (20) | | | 11 | | |
| | | (7030) | (6945) | (85) | | | 12 | | |
| | | 2 | 2,2'-Dihydroxybiphenyl | 3597 w | 3553 | 44 | 3470 w | 137 | Present work |
| | | | | 3597 w | 3554 | 43 | 3472 w | 135 | 13 |
| 3599 | 3556 | | | 43 | | | 7 | | |
| 3603 | 3560 | | | 43 | 3500 | 103 | 8a | | |
| (3610) | (3560) | | | (50) | (3470) | (140) | 11 | | |
| 3 | 2-Hydroxy-2'-methoxybiphenyl | 3608 | 3560 | 48 | 3450 | 158 | 8a | | |
| 4 | 2,2'-Dihydroxy-1,1'-binaphthyl | 3598 w | 3537 | 61 | None | | Present work | | |
| | | (3603) | (3548) | (55) | None | | 8a | | |

^a Values in parentheses were determined with instruments having sodium chloride optics and are believed to be less accurate than those determined with lithium fluoride or grating instruments; cf. ref. 16b. ν -values are given in cm^{-1} . w = weak absorption.

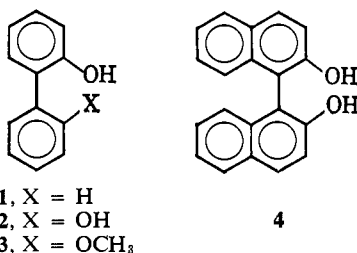
Table II. Spectroscopic Data for Methylolbiphenyls^a

| No. | Compound | ν free | ν OH \cdots π | $\Delta\nu$ | ν OH \cdots O | $\Delta\nu$ | Ref. |
|-----|---------------------------------|---------------|----------------------------|-------------|------------------------|-------------|---------------------------|
| 5 | Benzyl alcohol | 3632 sh | 3615 | 17 | | | 14a |
| | | 3636 sh | 3617 | 19 | | | 14b |
| 6 | 2-Phenylbenzyl alcohol | 3634 sh | 3619 | 15 | | | 13 |
| 7a | Biphenyl, 2,2'-dimethylol | 3635 sh | 3613 | 22 | 3477 | 158 | Present work |
| 7b | 6,6'-Dimethyl- | 3630 sh | 3610 | 20 | 3471 | 159 | Present work |
| 7c | 6,6'-Dichloro- | 3632 sh | 3613 | 19 | 3472 | 160 | Present work |
| 7d | 6,6'-Dinitro- | 3631 sh | 3613 | 18 | None | | Present work |
| 8 | 2,2'-Dimethylol-1,1'-binaphthyl | 3631 sh | 3610 | 21 | 3471 | 160 | Present work |
| 9a | 2-Hydroxy-2'-methylolbiphenyl | 3635 sh | 3619 | 16 | 3493 | 142 | Present work |
| 9b | | 3634 sh | 3615 | 19 | 3482 | 152 | Present work |
| 10 | | 3636 sh | 3623 sh | 13 | None | | Present work ^b |
| | | 3608 | 3558 | 50 | 3364 | 244 | Present work ^c |

^a ν -values in cm^{-1} . sh = shoulder. ^b Benzylic hydroxyl bands. ^c Phenolic hydroxyl bands (see text).

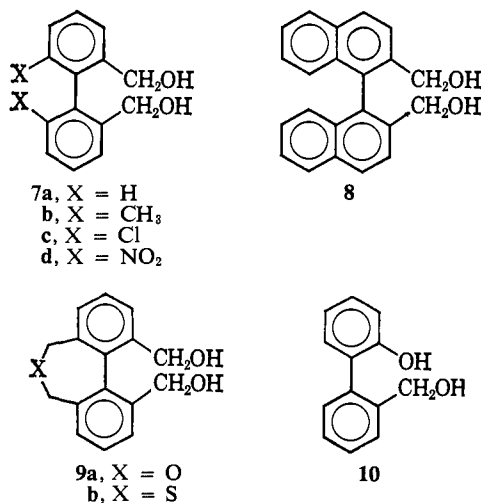

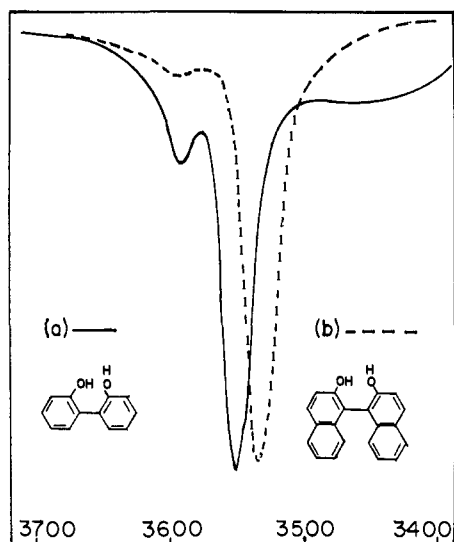
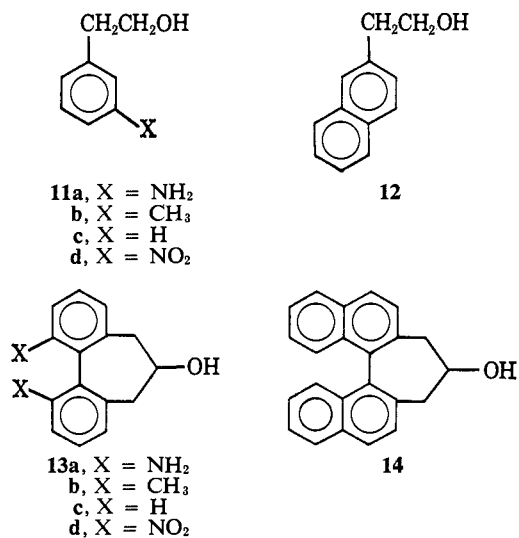

Figure 1. Spectra of dihydroxybiaryls. The abscissa is in cm.^{-1} here and in the following figures.

Table III. Spectroscopic Data for 2-Phenylethanol Derivatives^a

| No. | Compound | ν free OH | ν OH $\cdots\pi$ | $\Delta\nu$ | Ref. |
|-----|------------------------------------|------------------|-------------------------|-------------|--------------|
| 11a | 2-(<i>m</i> -Aminophenyl)ethanol | 3635 | 3598 | 37 | 16a |
| 11b | 2-(<i>m</i> -Methylphenyl)ethanol | 3636 | 3603 | 33 | 16a |
| 11c | 2-Phenylethanol | 3636 | 3606 | 30 | 16a |
| 11d | 2-(<i>m</i> -Nitrophenyl)ethanol | 3635 | 3615 | 20 | 16a |
| 12 | 2-(2'-Naphthyl)ethanol | 3632 | 3602 | 30 | 16b |
| 13a | | 3622 | 3585 | 37 | 8b |
| 13b | | 3622 | 3588 | 34 | Present work |
| 13c | | 3623 | 3590 | 33 | Present work |
| 13d | | 3619 | 3594 | 25 | Present work |
| 14 | | 3621 | 3589 | 32 | Present work |

^a ν -values in cm.^{-1} .



The relative intensity of this OH \cdots O band is enhanced in the monomethyl ether 3^{8a} as expected, but there is no evidence of such an OH \cdots O interaction in 2,2'-dihydroxy-1,1'-binaphthyl (4, Figure 1b) or in other 6,6'-substituted 2,2'-dihydroxybiphenyl derivatives.^{8a} This behavior has been interpreted as indicating the

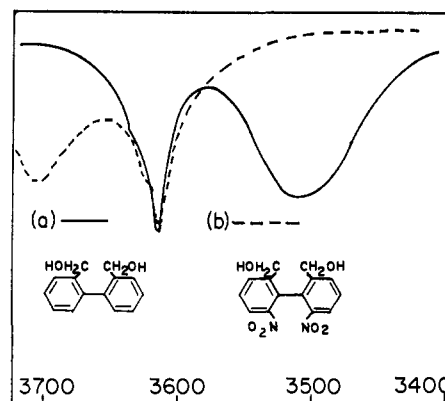

Figure 2. Spectra of dimethylolbiphenyls.

presence of a reasonable population of molecules with the *cis* conformation II (X = OH) in compounds 2 and 3, but that repulsion between 6- and 6'-substituents, when present, restricts the allowable conformations in which OH \cdots O interactions are possible.^{8a} Musso and his co-workers have presented additional examples of this type.⁸

The compounds of greatest interest to us here, 2,2'-dimethylolbiphenyl (7a) and its derivatives, appear not to have been examined before for hydrogen bonding characteristics. The spectrum of 7a (Figure 2a) is readily interpretable. The high frequency absorption consists of a peak at 3613 cm.^{-1} (OH $\cdots\pi$) and a shoulder at 3635 cm.^{-1} (free OH), reminiscent of the spectrum of benzyl alcohol (5).¹⁴ There is no evidence for OH $\cdots\pi$ hydrogen bonding between the hydroxyl group attached to one ring and the π -electrons of the other. This is confirmed by the spectrum of 2-phenylbenzyl alcohol (6) which shows only benzyl alcohol type absorption. The low frequency peak of 7a (Figure 2a) at 3477 cm.^{-1} must therefore be due to OH \cdots O hydrogen bonding. The magnitude of the spectral shift, $\Delta\nu$ 158 cm.^{-1} , is consistent with this interpretation.¹⁵

With one exception, the other 2,2'-dimethylolbiphenyls examined (Table II) gave spectra which differed only in minor ways from that of the parent compound, 7a. The exception, 6,6'-dinitro-2,2'-dimethylolbiphenyl (7d), did not give a low frequency OH \cdots O band in the infrared (Figure 2b). It is reasonable to conclude that this compound differs conformationally from the others in this series. Because of the limited solubility of 7d and the extremely dilute conditions of spectral measurement, the presence of a water band near 3700 cm.^{-1} in the spectrum of this compound (Figure 2b) was unavoidable. Numerous control experiments showed that such traces of water had no significant effect on the appearance of the remainder of the spectrum and did not influence the intramolecular association phenomena described here.

2-Hydroxy-2'-methylolbiphenyl (10) is a compound intermediate in type between the two classes already considered. The hydrogen bonding infrared spectrum (Figure 3) is particularly rich in detail. The benzyl-

(14) (a) P. von R. Schleyer, D. S. Trifan, and R. Bacskai, *J. Am. Chem. Soc.*, **80**, 6691 (1958); (b) M. Ōki and H. Iwamura, *Bull. Chem. Soc. Japan*, **32**, 950, 955 (1959).

(15) Cf. W. F. Baitinger, Jr., and P. von R. Schleyer, *J. Org. Chem.*, **29**, 989 (1964); L. P. Kuhn, P. von R. Schleyer, W. F. Baitinger, Jr., and L. Ebersson, *J. Am. Chem. Soc.*, **86**, 650 (1964).

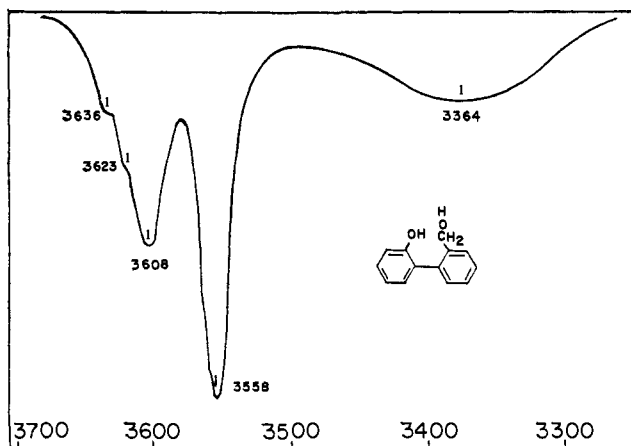

Figure 3. Spectrum of 2-hydroxy-2'-methylbiphenyl.

type hydroxyl has an $\text{OH} \cdots \pi$ band at about 3623 cm^{-1} and a free peak at about 3636 cm^{-1} ; both of these absorptions appear as shoulders on a more intense peak at 3608 cm^{-1} , due to the free phenolic hydroxyl. Two additional bands remain to be assigned. By comparison with Table I and Figure 1, the 3558 cm^{-1} band is seen to be due to a phenolic $\text{OH} \cdots \pi$ phenyl hydrogen bond, while the broad absorption centering at about 3364 cm^{-1} must be due to a phenolic $\text{OH} \cdots \text{O}$ -benzylic interaction. The very large magnitude of $\Delta\nu$ in this instance, 244 cm^{-1} , rules out the alternative benzylic $\text{OH} \cdots \text{O}$ -phenolic type of hydrogen bonding. The orientation observed for this $\text{OH} \cdots \text{O}$ interaction is perfectly reasonable; the more acidic phenolic hydroxyl is functioning as proton donor and the more basic oxygen in the CH_2OH group as proton acceptor.

The availability of 2,2'-bridged biphenyls with a hydroxyl group attached to the central atom of the three carbon bridge (13-14) prompted their inclusion in this study. Molecular models indicate that the fixed conformation adopted by these molecules, with the OH groups virtually imbedded in the π -electron cloud of an adjacent aryl ring, should be a particularly good one for intramolecular association.¹⁶ A comparison between the spectrum of 1,2,3,4-dibenz-1,3-cycloheptadien-6-ol (13c) and that of the simple model compound, 2-phenylethanol (11c), can be made by inspection of Figure 4a and 4b. Similar comparisons are possible from the data presented in Table III.

Discussion

Hydroxybiphenyls. The hydrogen bonding infrared spectra of 2,2'-dihydroxybiphenyl (2) and its derivatives (Figure 1) supports what is known about the conformation of biphenyl compounds in solution. The presence in 2 of both $\text{OH} \cdots \pi$ and $\text{OH} \cdots \text{O}$ type of hydrogen bonds is consistent with the assumption that a substantial population of molecules have the *cis* conformation II ($\text{X} = \text{OH}$). $\text{OH} \cdots \text{O}$ hydrogen bonding is not possible when the OH groups are *trans* (III, $\text{X} = \text{OH}$). Even in the 90° conformation I, the distance between oxygen atoms, 3.8 \AA . (Dreiding

(16) (a) M. Oki and H. Iwamura, *Bull. Chem. Soc. Japan*, **32**, 1135 (1959); (b) P. von R. Schleyer, C. Wintner, D. S. Trifan, and R. Bacskai, *Tetrahedron Letters*, No. 14, 1 (1959).

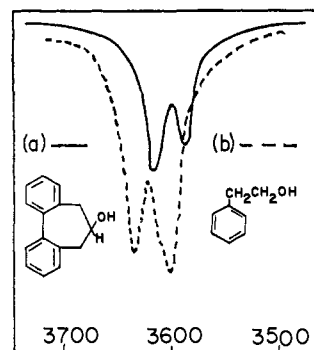
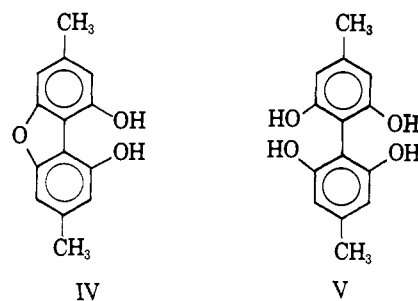

Figure 4. Spectra of β -arylethanolols.

models), is much too great to permit such an interaction.^{15,17}

Were the biphenyl system planar in solution, there would be no possibility of $\text{OH} \cdots \pi$ hydrogen bonding between the OH group attached to one ring and the π -electrons of the other. An example of this has been provided by Musso and von Grunelius.^{8a} The oxygen-bridged biphenyl IV must be planar or nearly so. No $\text{OH} \cdots \pi$ hydrogen bonding was observed in the infrared spectrum of this molecule, but $\text{OH} \cdots \text{O}$ interactions were found to be particularly strong.^{8a}



The spectrum of 2,2'-dihydroxy-1,1'-binaphthyl (4, Figure 1b) shows no $\text{OH} \cdots \text{O}$ hydrogen bonding, but the $\text{OH} \cdots \pi$ peak has increased in intensity and in magnitude of the spectral shift over that of 2 (Figure 1a). A reasonable interpretation of the behavior of 4, which is shared by other 6,6'-disubstituted 2,2'-dihydroxybiphenyls,⁸ is that serious interactions between the 6- and 6'-substituents either favor the *trans* conformation III ($\text{X} = \text{OH}$) or a nearly perpendicular conformation (as I) in which $\text{OH} \cdots \text{O}$ hydrogen bonding is impossible. Such a nearly perpendicular conformation should favor $\text{OH} \cdots \pi$ bonding. It is particularly noteworthy that even the 2,2',6,6'-tetrahydroxybiphenyl derivative V shows no $\text{OH} \cdots \text{O}$ hydrogen bonding in the infrared.^{8a} This is possible only if the molecule adopts a nearly perpendicular conformation (dihedral angle between the rings greater than about $60\text{--}70^\circ$, which is equivalent to $\text{O} \cdots \text{O}$ distances greater than about 3.3 \AA).^{15,17}

Methylolbiphenyls. In 2,2'-dimethylolbiphenyl (7a) and derivatives of similar structure (Table II) there exist two intramolecular hydrogen bonding possibilities besides interactions of the benzylic alcohol type.¹⁵ The first of these, $\text{OH} \cdots \pi$ hydrogen bonding between

(17) G. C. Pimentel and A. L. McClellan, "The Hydrogen Bond," W. H. Freeman and Co., San Francisco, Calif., 1960.

the hydroxyl group attached to one ring and the π -electrons of the other, is not observed, even in the simple model compound 2-phenylbenzyl alcohol (5). This is general behavior for 2-substituted benzyl alcohols¹⁶ and can be attributed to the preferred orientation of the hydroxyl group of the hydroxymethyl function away from the adjacent *ortho* substituent, because of steric hindrance.

The second potential type of hydrogen bonding, between the two OH groups, is of most interest to us here. It is this interaction which provides a convenient test for the conformational conclusions drawn from o.r.d. studies,⁵ and which demonstrates the utility of hydrogen bonding in such applications. Examination of models (Cenco-Peterson) of 2,2'-dimethylbiphenyls permits an estimate to be made of the O...O and OH...O distances corresponding to various rotational angles (ϕ) between the two rings. Results of these measurements are given in Table IV.

Table IV. Relationship of O...O and OH...O Distances to the Rotational Angle, ϕ , in 2,2'-Dimethylbiphenyls

| ϕ , deg. | O...O distance, Å. | OH...O distance, Å. |
|---------------|----------------------|----------------------|
| 0 | <i>a</i> | <i>a</i> |
| 45 | 0-5 ^b | 0-4 ^b |
| 90 | 2.0-2.4 ^c | 1.0-1.2 ^c |
| 135 | 4.2 ^d | 3.2 ^d |
| 180 | 5.8 ^d | 4.2 ^d |

^a Severe nonbonded interactions make this conformation very unlikely. ^b A great variety of bonded conformations possible, but none with all parameters optimum. ^c Minimum distances; all parameters can be optimum. ^d Minimum distances, but these are too great to permit hydrogen bonding.

The literature suggests that the optimum geometry for an OH...O hydrogen bond is: O...O distance about 2.5 Å., O-H...O angle 180°, and H...O-C angle 110°.^{15,17} When $\phi = 90^\circ$, these three geometrical requirements can be satisfied simultaneously. At $\phi < 90^\circ$ many conformations permitting hydrogen bonding are possible, but none of them can possess all three of the optimum values. At $\phi > 90^\circ$ the distance between the two bonding groups rapidly becomes too large for intramolecular association (Table IV). One can conclude from this analysis that hydrogen bonding should be best when ϕ is near 90° (I), but that such intramolecular interactions should also be present in *cis* (II, X = CH₂OH) but not in *trans* conformations (III, X = CH₂OH). A similar treatment has been used to explain the differences in hydrogen bonding behavior between 1,2-diols (which are analogous to 2,2'-dihydroxybiphenyls) and similarly constituted 1,4-diols (analogous to 2,2'-dimethylbiphenyls).¹⁵

In the o.r.d. studies carried out previously,⁵ no conclusions could be reached concerning the conformation of compounds 7a-c and 8 relative to those of the *cis*-restricted compounds 9. These latter are limited conformationally because of the presence of the constraining bridges; independent determinations indicate that the rotational angles are fixed at 44° (for 9a) and 57° (for 9b).⁵ The hydrogen bonding method proves to be superior to o.r.d. in this instance. All of the compounds 7a-c, 8, and 9 gave an OH...O hydrogen bonding band in their infrared spectrum

(Table II), suggesting that all are of the same conformational type. The magnitudes of the spectral shifts for these compounds provides additional information. For 9a with $\phi = 44^\circ$, $\Delta\nu$ is 142 cm.⁻¹. When the angle between the rings is enlarged ($\phi = 57^\circ$ for 9b), $\Delta\nu$ (152 cm.⁻¹ for 9b) increases. For the conformationally unrestrained molecules 7a-c $\Delta\nu$ is 159 \pm 1 cm.⁻¹, a value which indicates that ϕ is greater than 60° and probably is close to 90°, the optimum value for hydrogen bonding (Table IV). Earlier ultraviolet spectral data also indicate that biphenyls of this type have rings which are nearly perpendicular.^{4,5}

It should be pointed out that electronic effects of the various substituents attached to the biphenyls of Table II probably are not important in influencing the magnitudes of $\Delta\nu$. This is because of the dual nature of the CH₂OH groups, which must function as proton donors and as proton acceptors. The substituent electronic effects largely cancel out.¹⁵ For example, in a 2,2'-dimethylbiphenyl with the same electron-withdrawing groups at 6 and 6', the proton-donating abilities of the CH₂OH groups will be enhanced but the proton-accepting abilities of the same groups will be decreased, fortuitously to about the same extent. Thus, 7a-c and 8 all have virtually the same $\Delta\nu$.

O.r.d. studies indicated that the dinitrobiphenyl 7d is exceptional, and that it exists in the *trans* conformation (III, X = CH₂OH, Y = NO₂).⁵ This conclusion is confirmed by the infrared spectrum (Figure 2b); 7d showed no intramolecular OH...O hydrogen bond, and this compound is quite unique in this respect (Table II) due, evidently, to electrostatic repulsions between the nitro groups. In the *trans* conformation (III, X = CH₂OH, Y = NO₂), hydrogen bonding between the CH₂OH and NO₂ groups on different rings is a possibility, but this was not observed (Figure 2b). At best, nitro groups are very weak proton acceptors.¹

Other Compounds. The hydrogen bonding spectrum (Figure 3) of 10 showed the presence of an OH...O intramolecular interaction. This compound, too, exists in the *cis* conformation.

The biphenyls 13 and 14 with single OH groups substituted symmetrically in the three carbon bridges gave quite characteristic OH... π hydrogen bonding spectra (Figure 4 and Table III). Bridging in these biphenyls fixes the OH groups directly above the plane of one of the aromatic rings at an optimum distance for such hydrogen bonding. Compounds 13 and 14 are, in a formal sense, 2-phenylethanols, and a comparison between analogously substituted molecules is possible from Table III. It is seen that both the bridged biphenyls (13 and 14) and the 2-phenylethanols (11 and 12) have nearly identical $\Delta\nu$ values and both series respond similarly to changes of substituents.¹⁶ The correspondence of $\Delta\nu$ values for the 2-phenylethanols (11 and 12) and the bridged biphenyls (13 and 14) is fortuitous, however. The latter compounds are secondary alcohols, which are less acidic than primary alcohols and generally give smaller hydrogen bonding $\Delta\nu$ values.¹⁶ Considering this factor, the hydrogen bonded interactions for the bridged biphenyls appear stronger than normal, as might be expected from the particularly favorable geometry for intramolecular hydrogen bonding possessed by these compounds.

Experimental

Infrared Spectral Measurements. A Perkin-Elmer Model 21 spectrophotometer equipped with a LiF prism and a Perkin-Elmer Model 421 grating spectrophotometer were used for determination of the infrared spectra. The solvent, A.R. grade CCl_4 , was decanted from P_2O_5 before use. Matched silica cells, 1 or 2 cm. in length, permitted the observation of dilute solutions (0.005 M or less) and the use of different concentrations. The calibration of the instruments was checked daily against indigenous water vapor in the standard manner; the data reported are corrected. Samples were run at room temperature. The position of the peaks was evaluated by determining the center of the band envelope at various positions and averaging. Sharp peaks were determined with an accuracy of $\pm 1 \text{ cm.}^{-1}$; broad peaks and shoulders to ± 2 or 3 cm.^{-1} . The separation of the peaks, $\Delta\nu$, could be measured with an accuracy of $\pm 2 \text{ cm.}^{-1}$ since the difference was dependent on the relative and not the absolute position of the peaks. Reproducibility was shown to be good.

Sources of Compounds. Compounds **1**, **2**, and **4** were commercial samples, recrystallized before use. The preparation of **7a-d**, **8**, **9a,b**, **13b**, **13d**, and **14** has been reported earlier.⁵

2-Hydroxy-2'-methylbiphenyl (14). Reduction of the lactone of 2'-hydroxybiphenyl-2-carboxylic acid (m.p. $92-93^\circ$),¹⁸ prepared by the method of Emmons and Lucas,¹⁹ with LiAlH_4 in ether gave 2-hydroxy-2'-methylbiphenyl, m.p. $131.4-132.6^\circ$. *Anal.* Calcd. for $\text{C}_{13}\text{H}_{12}\text{O}_2$: C, 77.98; H, 6.04. Found: C, 77.58; H, 6.05.

1,2,3,4-Dibenz-1,3-cycloheptadien-6-ol (13c).²⁰ Reduction of 1,2,3,4-dibenz-1,3-cycloheptadien-6-one²¹ by LiAlH_4 in the usual manner gave a product which was distilled at 150° (0.1-0.5 mm.). Crystals formed on standing. Recrystallization from cyclohexane gave material, m.p. $81.5-82.5^\circ$. *Anal.* Calcd. for $\text{C}_{15}\text{H}_{14}\text{O}$: C, 85.68; H, 6.71. Found: C, 85.34; H, 6.70.

Acknowledgment. One of us (P. R. S.) wishes to express appreciation for the hospitality extended to him at the Institute for Organic Chemistry of the University of Munich, where the final draft of this manuscript was written.

(18) Reported m.p. $91.5-92.5^\circ$; W. von E. Doering and L. Speers, *J. Am. Chem. Soc.*, **72**, 5515 (1950).

(19) W. Emmons and G. Lucas, *ibid.*, **77**, 2287 (1955).

(20) This compound was prepared by Dr. A. J. Gordon, at New York University.

(21) J. Kenner and E. G. Turner, *J. Chem. Soc.*, **99**, 2101 (1911).

Concerning the Mechanism of Acid-Catalyzed Hydrolysis of Ketals, Ortho Esters, and Orthocarbonates¹

A. M. Wenthe and E. H. Cordes

Contribution No. 1285 from the Department of Chemistry, Indiana University, Bloomington, Indiana. Received March 31, 1965

Proton magnetic resonance spectroscopy has been employed to follow simultaneously the kinetics of disappearance of methoxy protons of substrate, appearance of methyl protons of methanol, and appearance of methoxy protons of product for the hydrolysis of 2,2-dimethoxypropane, methyl orthobenzoate, 6,6,6-trimethoxyhexanonitrile, and methyl orthocarbonate in weakly acidic mixtures of deuterium oxide and methanol- d_4 at 25° . In all cases, the first-order rate constants for each of these reactions were approximately the same. This result is interpreted in terms of rate-determining carbonium ion formation. This conclusion is corroborated by the finding, from product analysis studies, that little exchange of the methoxy functions of substrate with deuteriomethoxy functions of solvent occurred in the course of hydrolysis. On the basis of kinetic and product analysis studies, deuteriomethanol and deuterium oxide appear to exhibit approximately equal reactivities toward the carbonium ions derived from the above substrates.

Introduction

Several independent lines of evidence strongly suggest that the acid-catalyzed hydrolysis of acetals,

ketals, ortho esters, and, by analogy, orthocarbonates proceeds by a reaction pathway not involving solvent as nucleophilic reagent (eq. 1). (i) These substrates are

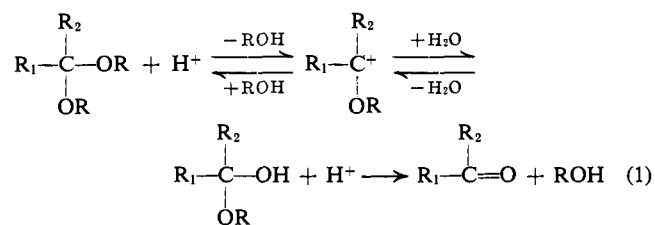

extremely resistant to nucleophilic attack by hydroxide ion and other nucleophilic reagents; (ii) volumes of activation for the acid-catalyzed hydrolysis of dimethoxymethane, dimethoxy- and diethoxyethane, and ethyl orthoformate are close to zero or slightly positive²; (iii) entropies of activation for the hydrolysis of several acetals, ketals, orthoformates, and orthobenzoates are near zero or slightly positive²⁻⁷; (iv) the

(2) J. Koskikallio and E. Whalley, *Trans. Faraday Soc.*, **55**, 809 (1959).

(3) F. Brescia and V. K. LaMer, *J. Am. Chem. Soc.*, **62**, 612 (1940).

(4) P. M. Leininger and M. Kilpatrick, *ibid.*, **61**, 2510 (1939).

(5) R. H. DeWolfe and J. L. Jensen, *ibid.*, **85**, 3264 (1963).

(6) J. G. Fullington and E. H. Cordes, *J. Org. Chem.*, **29**, 970 (1964).

(7) L. L. Schaleger and F. A. Long, *Advan. Phys. Org. Chem.*, **1**, 1 (1963).

(1) Supported by grants from the National Science Foundation (GB-431) and from the National Institutes of Health (AM-08232-01).